



# KLT Box tool



Product Flyer

The KLT Box tool is designed for handling the widely used KLT storage boxes.

The tool's low height makes it possible to handle boxes on shelves with limited space above the boxes.

The tool is design for a number of KLT variants.

If the product does not match your your specific application or requirements, please contact us to discuss a customized tool.

Graspian ApS,  
Hørmarken 2,  
DK-3520 Farum,  
Denmark

Phone: +45 2812 1782  
Email: [sales@graspian.com](mailto:sales@graspian.com)  
Website: [www.graspian.com](http://www.graspian.com)

# Product specifications

General	Min.	Typ.	Max.	Units
Payload			5	kg
Tool weight			1	kg
Gripping time			1	sec
Overall dimensions	290 x 158 x 57			mm
Electrical interface	UR Tool port (24 VDC)			
Mechanical interface	ISO 9409-1-50-4-M6			

Operating conditions	Min.	Typ.	Max.	Units
Power supply	-	24	-	V
Current consumption	-		2	A
Operating temperature	5		50	°C
Rel. hum. (non-condensing)	0		95	%

Compliant boxes
AUER RL-KLT-4147
AUER RL-KLT-4280

# Dimensions

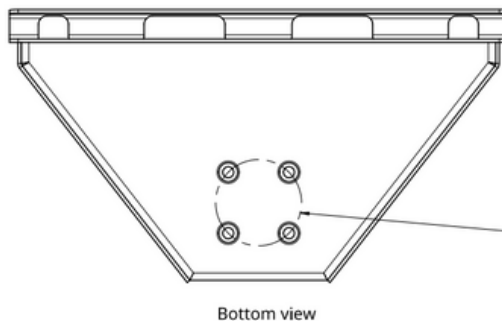
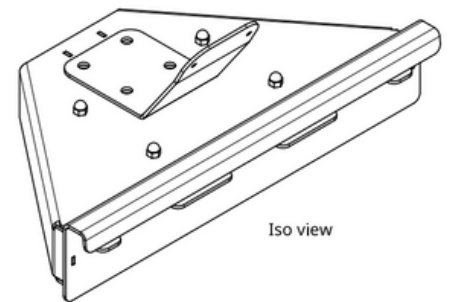
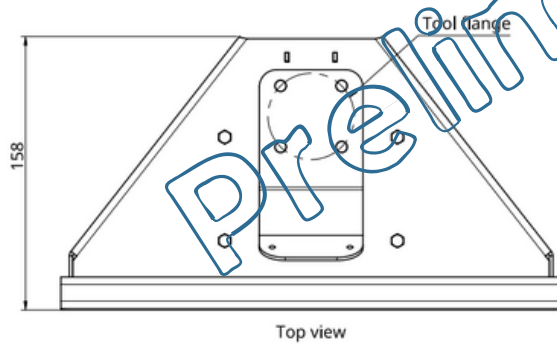
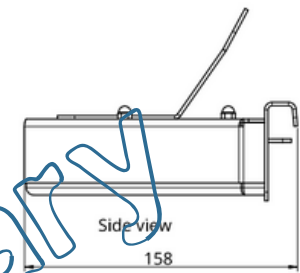
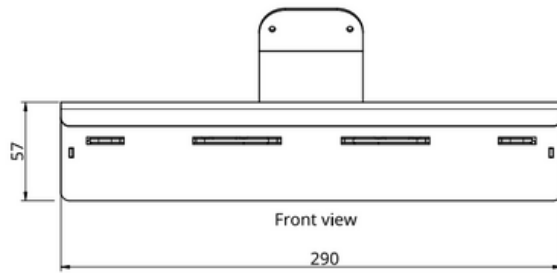

Tool flange mounting bolts  
Accessable without taking the tool apart.

Mounting bolt: DIN912 M6 x 8

Tightning torque: TBD (8Nm?)

